

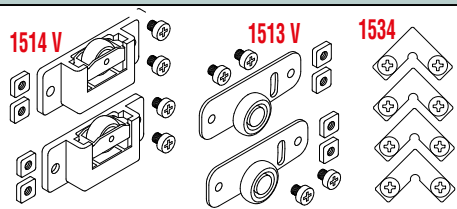





KIT 1514-1513 V - MAX 30 KG



Legenda KIT / Kit Legend

1513V	Carrello inferiore per profilo (art.1530) <i>Lower truck for profile (art.1530)</i>
1514V	Guida superiore per profilo (art.1530) <i>Upper runner for profile (art.1530)</i>
1534	Giunto per anta alluminio <i>Joint for aluminium door</i>

Legenda altri componenti Legend other items

1500		Profilo alluminio superiore e inferiore <i>Upper and lower aluminium profile</i>
1530		Profilo alluminio superiore e inferiore <i>Upper and lower aluminium profile</i>
1531		Profilo anta alluminio laterale <i>Side aluminium door profile</i>
1532		Guarnizione plastica <i>Plastic gasket</i>

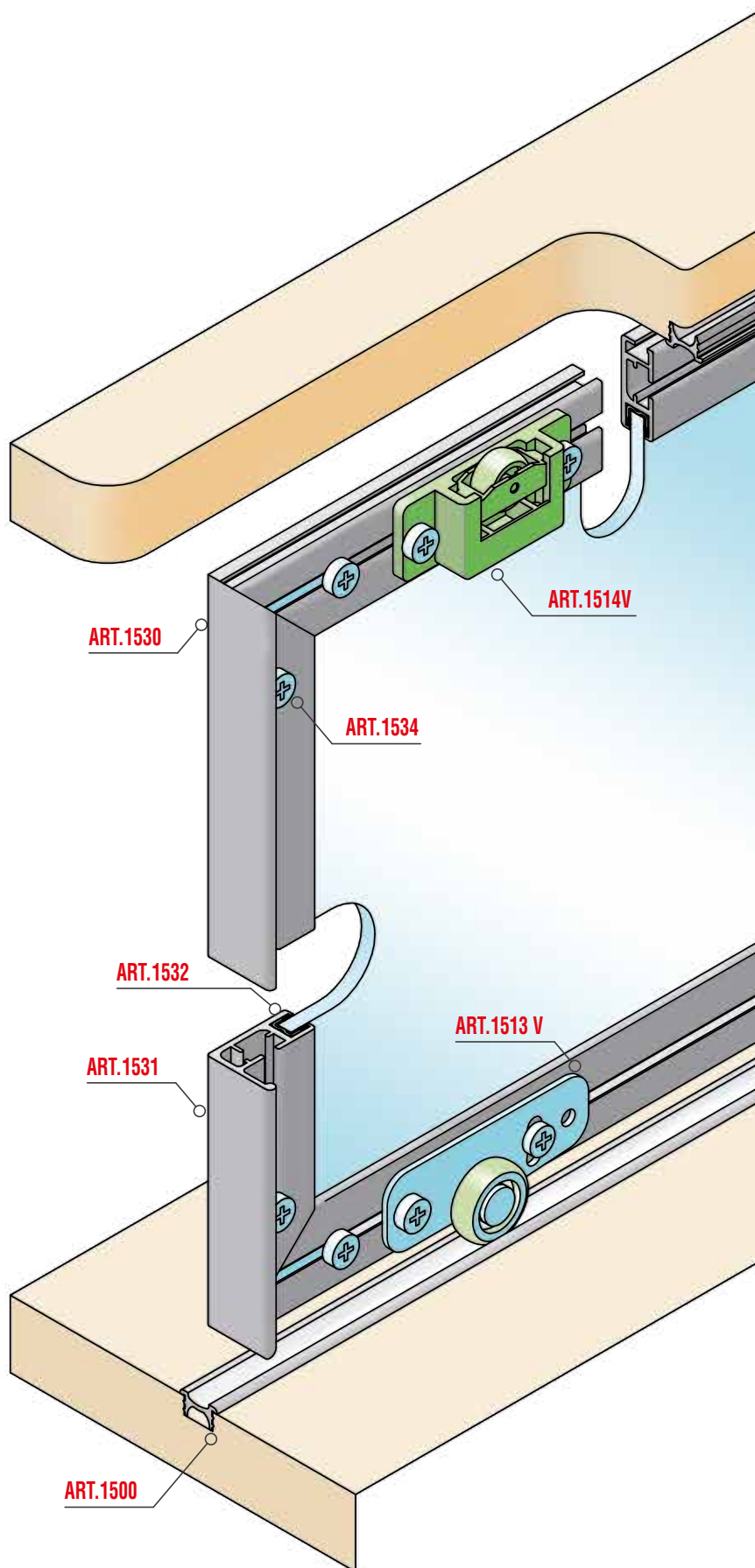



Sezione verticale / Vertical section

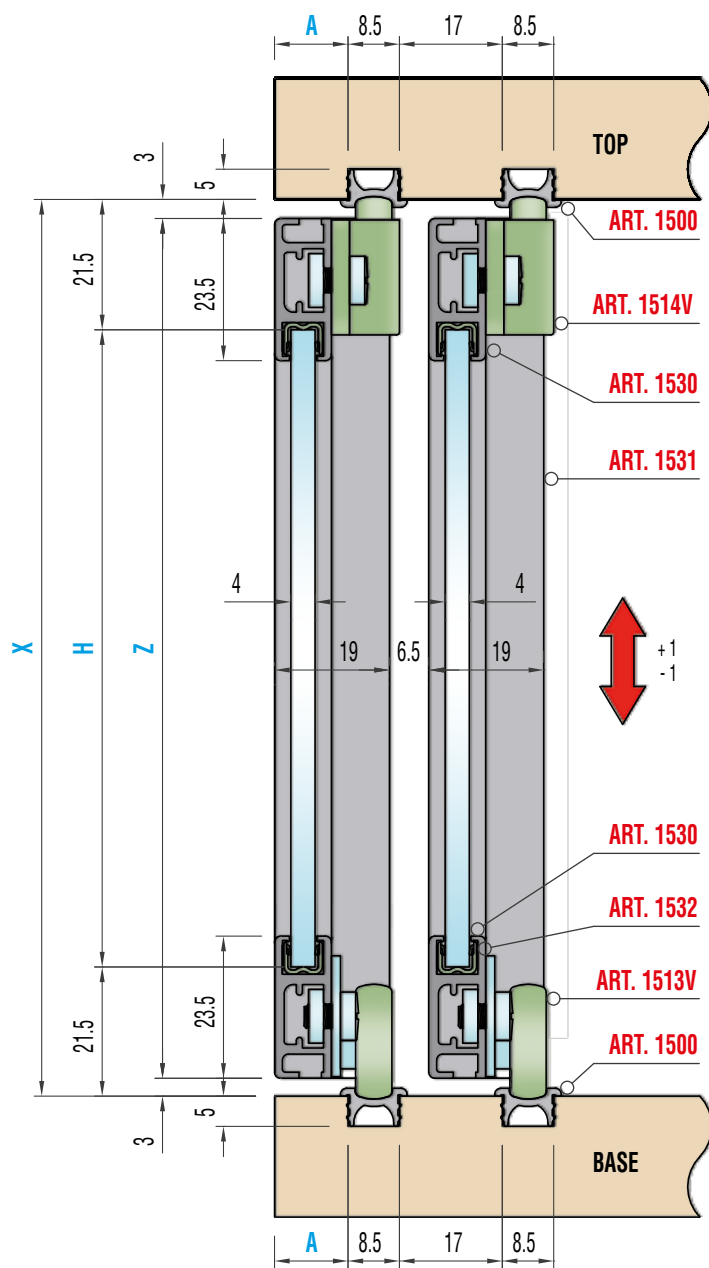

Peso massimo anta Kg. 30
Maximum door weight Kg 30

A = min. 12

Anta filo mobile A = 12 mm.
Door in line with the furniture edge A = 12 mm.

B =	K + 10,5
h =	X - 43 mm. = altezza pannello X - 43 mm. = panel height
Z =	X - 6 mm. = altezza antina X - 6 mm. = door height

Spessore pannello = 4 mm.
Panel thickness = 4 mm.

Altezza massima ante 1800 mm.
Maximum doors height 1800 mm.

Schema di montaggio / assembling

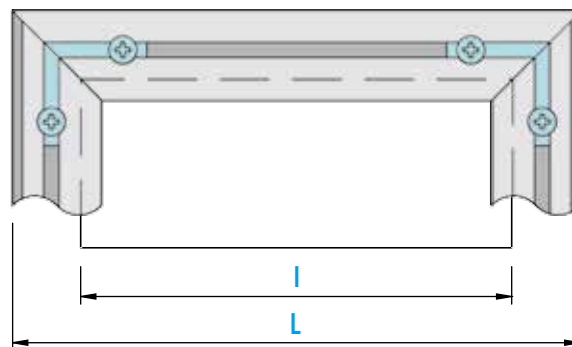

L = Larghezza anta / Door length

l = Larghezza pannello = L - 37 mm. / Panel length = L - 37 mm.

Schema montaggio carrelli / How to fit the trucks

